

Fig 14.60—Block diagram of a VHF/UHF NBFM transmitter using the indirect FM (phase modulation) method.

- Fall 1992 *Communications Quarterly*. Also see J. Kearman, "The Drake R-8 Shortwave Receiver," Mar 1992 *QST*, p 72.
- ²⁵R. Zavrel, "Using the NE602," Technical Correspondence, May 1990 *QST*.
- ²⁶R. Campbell, "A Single-Board, No-Tune 902 MHz Transverter," Jul 1991 *QST*.

- ²⁷Z. Lau, "A No-Tune 222 MHz Transverter," Jul 1993 *QEX*.
- ²⁸Z. Lau, "The Quest for 1 dB NF on 10 GHz," Dec 1992 *QEX*.
- ²⁹Z. Lau, "Home-Brewing a 10-GHz SSB/CW Transverter," May and Jun 1993 *QST*.
- ³⁰ARRL, *UHF/Microwave Exper-*

- imenter's Manual*, 1990, p 6-50.
- ³¹M. Schwartz, *Information Transmission, Modulation and Noise*, third edition, McGraw-Hill, 1980.
- ³²R. Healy, "The Omni VI Transceiver," Product Review, Jan 1993 *QST*, p 65.

A Rock-Bending Receiver for 7 MHz

This simple receiver by Randy Henderson, W15W, originally published in Aug 1995 *QST*, is a direct-conversion type that converts RF directly to audio. Building a stable oscillator is often the most challenging part of a simple receiver. This one uses a tunable crystal-controlled oscillator that is both stable and easy to reproduce. All of its parts are readily available from multiple sources and the fixed-value capacitors and resistors are common components available from many electronics parts suppliers.

THE CIRCUIT

This receiver works by mixing two radio-frequency signals together. One of them is the signal you want to hear, and the other is generated by an oscillator circuit (Q1 and associated components) in the receiver. In Fig 14.61, mixer U1 puts out sums and differences of these signals and their harmonics. We don't use the sum of the original frequencies, which comes out

of the mixer in the vicinity of 14 MHz. Instead, we use the frequency *difference* between the incoming signal and the receiver's oscillator—a signal in the audio range if the incoming signal and oscillator frequencies are close enough to each other. This signal is filtered in U2, and amplified in U2 and U3. An audio transducer (a speaker or headphones) converts U3's electrical output to audio.

How the Rock Bender Bends Rocks

The oscillator is a tunable crystal oscillator—a variable crystal oscillator, or VXO. Moving the oscillation frequency of a crystal like this is often called *pulling*. Because crystals consist of precisely sized pieces of quartz, crystals have long been called *rocks* in ham slang—and receivers, transmitters and transceivers that can't be tuned around due to crystal frequency control have been said to be *rockbound*. Widening this rockbound receiver's tun-

ing range with crystal pulling made *rock bending* seem just as appropriate!

L2's value determines the degree of pulling available. Using FT-243-style crystals and larger L2 values, the oscillator reliably tunes from the frequency marked on the holder to about 50 kHz below that point with larger L2 values. (In the author's receiver a 25-kHz tuning range was achieved.) The oscillator's frequency stability is very good.

Inductor L2 and the crystal, Y1, have more effect on the oscillator than any other components. Breaking up L2 into two or three series-connected components often works better than using one RF choke. (The author used three molded RF chokes in series—two 10- μ H chokes and one 2.7- μ H unit.) Making L2's value too large makes the oscillator stop.

The author tested several crystals at Y1. Those in FT-243 and HC-6-style holders seemed more than happy to react to adjustment of C7 (TUNING). Crystals in the

smaller HC-18 metal holders need more inductance at L2 to obtain the same tuning range. One tiny HC-45 unit from International Crystals needed 59 μH to eke out a mere 15 kHz of tuning range.

Input Filter and Mixer

C1, L1, and C2 form the receiver's input filter. They act as a peaked *low-pass*

network to keep the mixer, U1, from responding to signals higher in frequency than the 40-meter band. (This is a good idea because it keeps us from hearing video buzz from local television transmitters, and signals that might mix with harmonics of the receiver's VXO.) U1, a Mini-Circuits SBL-1, is a passive diode-ring mixer. Diode-ring mixers usually per-

form better if the output is terminated properly. R11 and C8 provide a resistive termination at RF without disturbing U2A's gain or noise figure.

Audio Amplifier and Filter

U2A amplifies the audio signal from U1. U2B serves as an active low-pass filter. The values of C12, C13 and C14 are

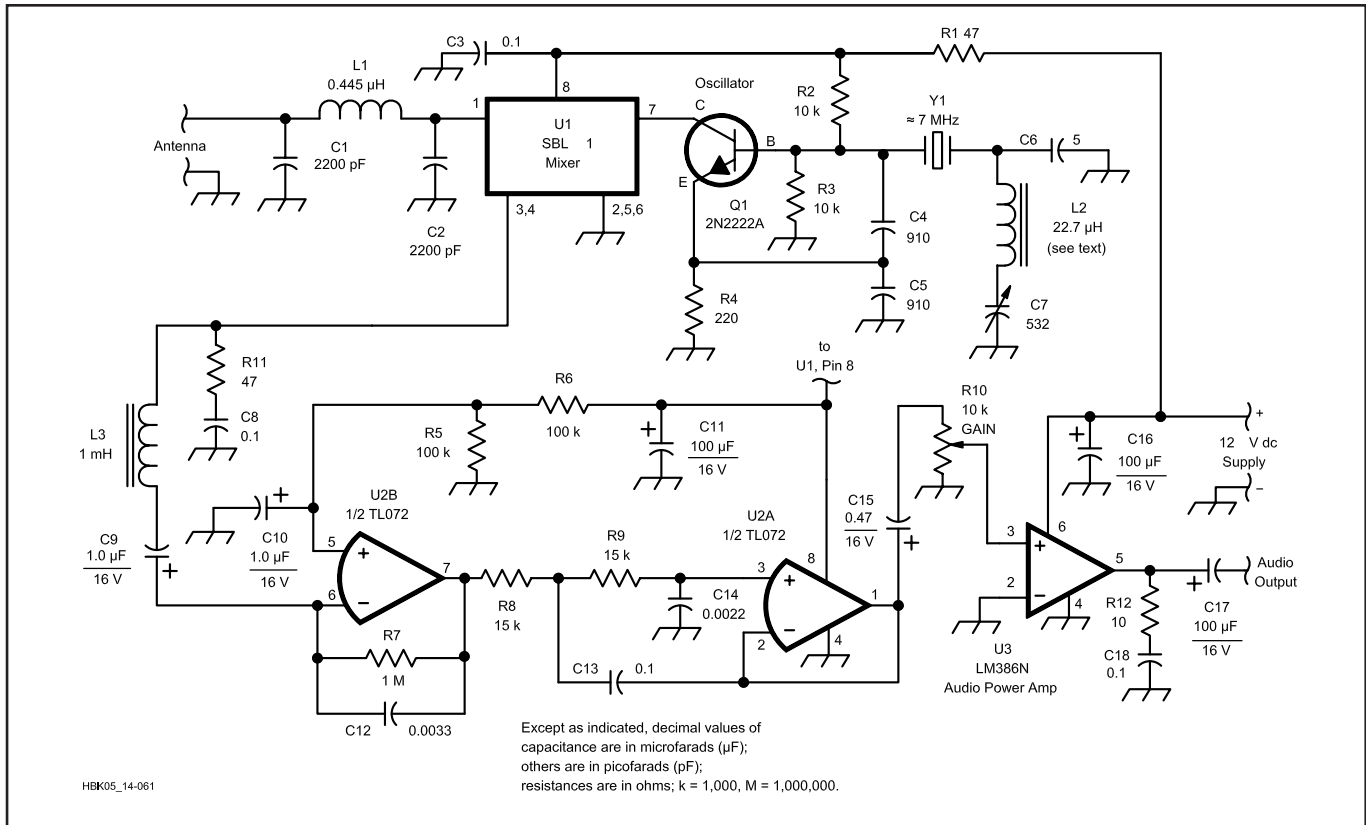

Fig 14.61—An SBL-1 mixer (U1, which contains two small RF transformers and a Schottky-diode quad), a TL072 dual op-amp IC (U2) and an LM386 low-voltage audio power amplifier IC (U3) do much of the Rock-Bending Receiver's magic. Q1, a variable crystal oscillator (VXO), generates a low-power radio signal that shifts incoming signals down to the audio range for amplification in U2 and U3. All of the circuit's resistors are 1/4-W, 5%-tolerance types; the circuit's polarized capacitors are 16-V electrolytics, except C10, which can be rated as low as 10 V. The 0.1- μF capacitors are monolithic or disc ceramics rated at 16 V or higher.

C1, C2—Ceramic or mica, 10% tolerance.

C4, C5, and C6—Polystyrene, dipped silver mica, or C0G (formerly NP0) ceramic, 10% tolerance.

C7—Dual-gang polyethylene-film variable (266 pF per section) available as #24TR218 from Mouser Electronics (800-346-6873, 817-483-4422). Screws for mounting C7 are Mouser #48SS003. A rubber equipment foot serves as a knob. (Any variable capacitor with a maximum capacitance of 350 to 600 pF can be substituted; the wider the capacitance range, the better.)

C12, C13, C14—10% tolerance. For SSB, change C12, C13 and C14 to 0.001 μF . U2—TL072CN or TL082CN dual JFET op amp.

L1—4 turns of AWG #18 wire on 3/4-inch PVC pipe form. Actual pipe OD is 0.85 inch. The coil's length is about 0.65 inch; adjust turns spacing for maximum signal strength. Tack the turns in place with cyanoacrylic adhesive, coil dope or Duco cement. (As a substitute, wind 8 turns of #18 wire around 75% of the circumference of a T-50-2 powdered-iron core. Once you've soldered the coil in place and have the receiver working, expand and compress the coil's turns to peak incoming signals, and then cement the winding in place.)

L2—Approximately 22.7 μH ; consists of one or more encapsulated RF chokes in series (two 10- μH chokes [Mouser #43HH105 suitable] and one 2.7- μH choke [Mouser #43HH276 suitable] used by author). See text

L3—1-mH RF choke. As a substitute, wind 34 turns of #30 enameled wire around an FT-37-72 ferrite core.

Q1—2N2222, PN2222 or similar small-signal, silicon NPN transistor.

R10—5 or 10-k Ω audio-taper control (RadioShack No. 271-215 or 271-1721 suitable).

U1—Mini-Circuits SBL-1 mixer.

Y1—7-MHz fundamental-mode quartz crystal. Ocean State Electronics carries 7030, 7035, 7040, 7045, 7110 and 7125-kHz units.

PC boards for this project are available from FAR Circuits.

appropriate for listening to CW signals. If you want SSB stations to sound better, make the changes shown in the caption for Fig 14.61.

U3, an LM386 audio power amplifier IC, serves as the receiver's audio output stage. The audio signal at U3's output is more than a billion times more powerful than a weak signal at the receiver's input, so don't run the speaker/earphone leads near the circuit board. Doing so may cause a squealy audio oscillation at high volume settings.

CONSTRUCTION

If you're already an accomplished builder, you know that this project can be built using a number of construction techniques, so have at it! If you're new to building, you should consider building the Rock-Bending Receiver on a printed circuit (PC) board. (The parts list tells where you can buy one ready-made.) See Fig 14.62 for details on the physical layout of several important components used in the receiver. Fig 14.63 shows photos of two different receivers using two different approaches to construction—one using a PC board and the other using “ugly” techniques.

If you use a homemade double-sided circuit board based on the PC pattern on the accompanying CD, you'll notice that it has more holes than it needs to. The extra holes (indicated in the part-placement diagram with square pads) allow you to connect its ground plane to the ground traces on its foil side. (Doing so reduces the inductance of some of the board's ground paths.) Pass a short length of bare wire (a clipped-off component lead is fine) into each of these holes and solder on both sides. Some of the circuit's components (C1, C2 and others) have grounded leads accessible on both sides of the board. Solder these leads on both sides of the board.

Another important thing to do if you use a homemade double-sided PC board is to countersink the ground plane to clear all ungrounded holes. (Countersinking clears copper away from the holes so components won't short-circuit to the ground plane.) A 1/4-inch-diameter drill bit works well for this. Attach a control knob to the bit's shank and you can safely use the bit as a manual countersinking tool. If you countersink your board in a drill press, set it to about 300 rpm or less, and use very light pressure on the feed handle.

Mounting the receiver in a metal box or cabinet is a good idea. Plastic enclosures can't shield the TUNING capacitor from the presence of your hand, which may slightly affect the receiver tuning. You don't have to completely enclose the receiver—a flat

aluminum panel screwed to a wooden base is an acceptable alternative. The panel supports the tuning capacitor, GAIN control and your choice of audio connector. The base can support the circuit board and antenna connector.

CHECKOUT

Before connecting the receiver to a power source, thoroughly inspect your work to spot obvious problems like solder bridges, incorrectly inserted components or incorrectly wired connections. Using the schematic (and PC-board layout if you built your receiver on a PC board), recheck every component and connection one at a time. If you have a digital voltmeter (DVM), use it to measure the resistance between ground and everything that should be grounded. This includes things like pin 4 of U2 and U3, pins 2, 5, 6 of U1, and the rotor of C7.

If the grounded connections seem all right, check some supply-side connections with the meter. The connection between pin 6 of U3 and the positive power-supply lead should show less than 1 Ω of resis-

tance. The resistance between the supply lead and pin 8 of U1 should be about 47 Ω because of R1.

If everything seems okay, you can apply power to the receiver. The receiver will work with supply voltages as low as 6 V and as high as 13.5 V, but it's best to stay within the 9 to 12-V range. When first testing your receiver, use a current-limited power supply (set its limiting between 150 and 200 mA) or put a 150-mA fuse in the connection between the receiver and its power source. Once you're sure that everything is working as it should, you can remove the fuse or turn off the current limiting.

If you don't hear any signals with the antenna connected, you may have to do some troubleshooting. Don't worry; you can do it with very little equipment.

TROUBLE?

The first clue to look for is noise. With the GAIN control set to maximum, you should hear a faint rushing sound in the speaker or headphones. If not, you can use a small metallic tool and your body as a

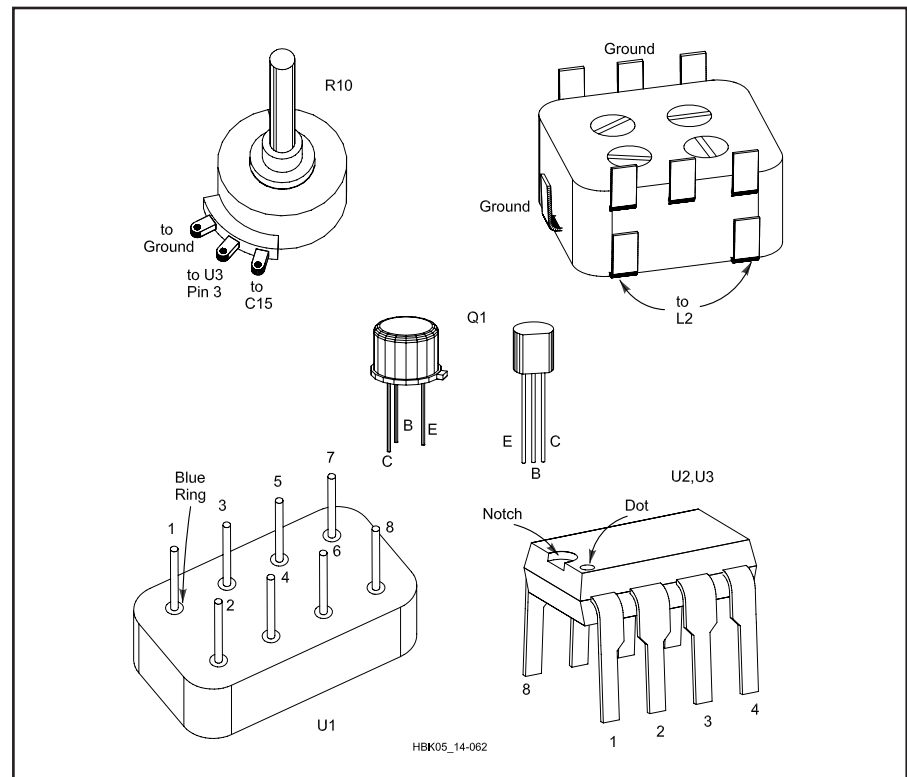

Fig 14.62—The Mouser Electronics part suggested for C7 has terminal connections as shown here. (You can use any variable capacitor with a maximum capacitance of 350 to 600 pF for C7, but its terminal configuration may differ from that shown here.) Two Q1-case styles are shown because plastic or metal transistors will work equally well for Q1. If you build your Rock-Bending Receiver using a prefab PC board, you should mount the ICs in 8-pin mini-DIP sockets rather than just soldering the ICs to the board.

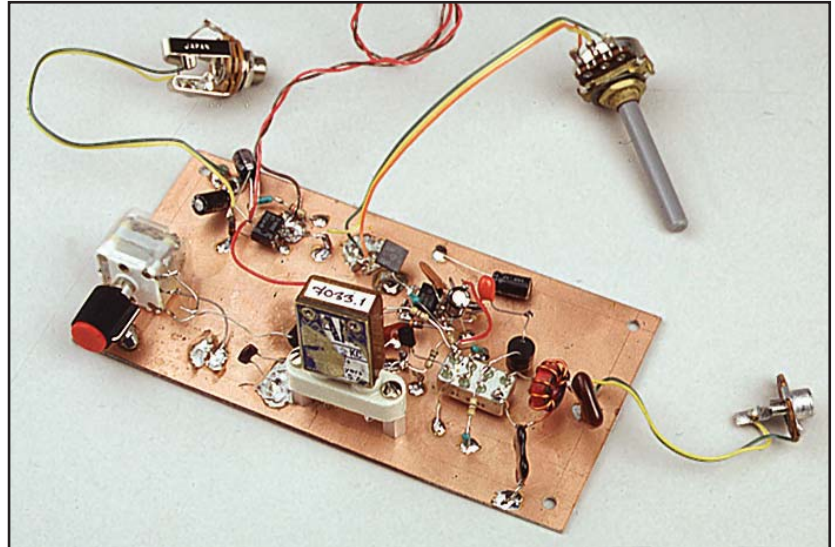
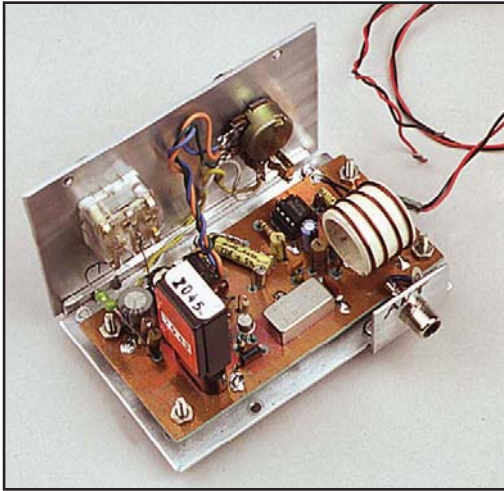

Fig 14.63—Ground-plane construction, PC-board construction—both of these approaches can produce the same good Rock Bending Receiver performance. (W15W built the one that looks nice, and ex-W9VES—who wrote this caption—built the one that doesn't.)

sort of test-signal generator. (If you have any doubt about the safety of your power supply, power the Rock-Bending Receiver from a battery during this test.) Turn the GAIN control to maximum. Grasp the metallic part of a screwdriver, needle or whatever in your fingers, and use the tool to touch pin 3 of U3. If you hear a loud scratchy popping sound, that stage is working. If not, then something directly related to U3 is the problem.

You can use this technique at U2 (pin 3, then pin 5) and all the way to the antenna. If you hear loud pops when touching either end of L3 but not the antenna connec-

tor, the oscillator is probably not working. You can check for oscillator activity by putting the receiver near a friend's transceiver (both must be in the same room) and listening for the VXO. Be sure to adjust the TUNING control through its range when checking the oscillator.

The dc voltage at Q1's base (measured without the RF probe) should be about half the supply voltage. If Q1's collector voltage is about equal to the supply voltage, and Q1's base voltage is about half that value, Q1 is probably okay. Reducing the value of L2 may be necessary to make some crystals oscillate.

OPERATION

Although the Rock-Bending Receiver uses only a handful of parts and its features are limited, it performs surprisingly well. Based on tests done with a Hewlett-Packard HP 606A signal generator, the receiver's minimum discernible signal (by ear) appears to be $0.3 \mu\text{V}$. The author could easily copy $1\text{-}\mu\text{V}$ signals with his version of the Rock-Bending Receiver.

Although most HF-active hams use transceivers, there are advantages in using separate receivers and transmitters. This is especially true if you are trying to assemble a simple home-built station.

A Wideband MMIC Preamp

This project illustrates construction techniques used in the microwave region (at and beyond 1 GHz). It also results in a neat "dc to daylight" preamplifier with many uses around your shack, not the least of which is monitoring the downlinks from Amateur Radio satellites. The original article was written by William Parmley, KR8L, in Nov 1997 *QST*.

The preamplifier uses the MAR-6 monolithic microwave integrated circuit (MMIC) manufactured by Mini-Circuits Labs. The MAR-6 is a four terminal, surface mount device (SMD) with an operating frequency range from dc to 2 GHz, a noise figure of 3 dB, a gain of up to 20 dB,

and input and output impedances of 50Ω . The basic concept for the preamplifier and the construction techniques used to build it came from *The ARRL UHF/Microwave Experimenter's Manual*. The parts and circuit board material in this project are readily available from sources such as Ocean State Electronics.

CIRCUIT DESCRIPTION

Fig 14.64 is the schematic for the preamplifier. C1 and C2 are dc blocking capacitors. The device receives at the output lead, through RF choke L1 and limiting resistor R1. The only other components used are the bypass capacitors on the lead.

C1 and C2 should present a low impedance at the lowest signal frequency of interest. The author designed his preamplifier for 435 MHz, a downlink frequency for many amateur satellites. Two 220 pF disc ceramic capacitors were used for C1 and C2. To use the preamplifier at 29 MHz for downlink signals from Russian RS-series satellites, C1 and C2 become $0.001 \mu\text{F}$ disc ceramic capacitors.

The power-supply voltage determines R1's value. The MAR-6 draws about 16 mA, and needs a V_{cc} of about 3.5 V. Use Ohm's Law to calculate the necessary voltage drop from your power supply voltage down to 3.5 V. The author's power